

The Axon® EZ-Seal® 600SL Heat Shrinkable Sleeve Label Applicator

The EZ-Seal® 600SL dual head sleeve label application system applies sleeve labels at speeds exceeding 600 cpm. Setting a new standard for value, simplicity, reliability and ease of operation, this new machine provides high production rates at minimal costs for most full body sleeve applications. Depending on container configurations the EZ-Seal® 600SL is designed to accommodate product widths from 1-11/16" to 4-5/8". The system operates in either single or dual applicator head mode, providing redundant operational security for high speed production lines.

The patented cutting assembly provides high productivity and long blade life. Touch screen operator interface offers ease of operation and system control. Axon® can supply a variety of heat tunnel and conveyor options to suit your needs.

[Video Button](#)

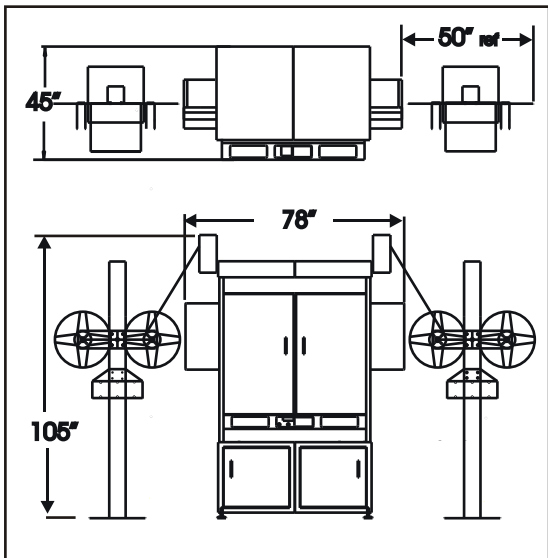

® EZ-Seal® 600SL features and benefits:

- PLC controls
- Dual head operation
- User friendly touch screen operator interface
- Servo drive film feeding and cutting systems
- Stainless steel enclosure
- Thin gauge film capability.
- Quick and easy container size changes

Max Rate	Sleeve Layflat	Sleeve Thickness	Electrical 220 V 3 Phase	Weight
600 bpm	72-190 mm	35 - 70 micron	20 amp	3500 lbs

*Speeds depend on width and length of sleeve
Options available upon request

PROTECTED UNDER ONE OR MORE OF THE FOLLOWING U.S. PATENTS: 5,165,215 5,197,259 5,305,578 5,417,794 5,448,876 5,495,704 5,711,135 6,263,940 6,505,457 6,543,514 6,775,957 AND OTHER PATENTS PENDING

Axon® Corporation

3080 Business Park Drive, Suite 103, Raleigh, NC 27610 • Tel: 919-772-8383 • Fax: 919-772-5575 • Toll Free: 800-598-8601
E-Mail: info@axoncorp.com • Web: www.axoncorp.com